

4

3

2

1

THIS DRAWING IS UNPUBLISHED. RELEASED FOR PUBLICATION 20
 © COPYRIGHT 20 BY TYCO ELECTRONICS CORPORATION. ALL RIGHTS RESERVED.

LOC	DIST	REVISIONS					
CE	00	P	LTR	DESCRIPTION	DATE	DWN	APVD
		D		REV PER ECR-07-000261	12MAR2007	DHR	DHR
		DI		REMOVED LOGOS ON VIEWS	14MAR2007	DHR	DHR
		E		REVISE PER ECR 07-008306	20APR2007	BB	CB
		F		REVISE PER ECR-08-017519	15JUL2008	BB	CB

△ MATERIAL:
 HOUSING: THERMOPLASTIC, UL 94-V0
 PROTECTIVE PLUGS: THERMOPLASTIC ELASTOMER
 ALIGNMENT SLEEVES: SEE TABLE
 RETENTION CLIP: SST

- 2. DUPLEX PROTECTIVE PLUGS ARE SUPPLIED, NOT SHOWN.
- △ 3. RETENTION CLIP IS NOT INCLUDED.
- △ 4. ADAPTER HAS A LOGO.

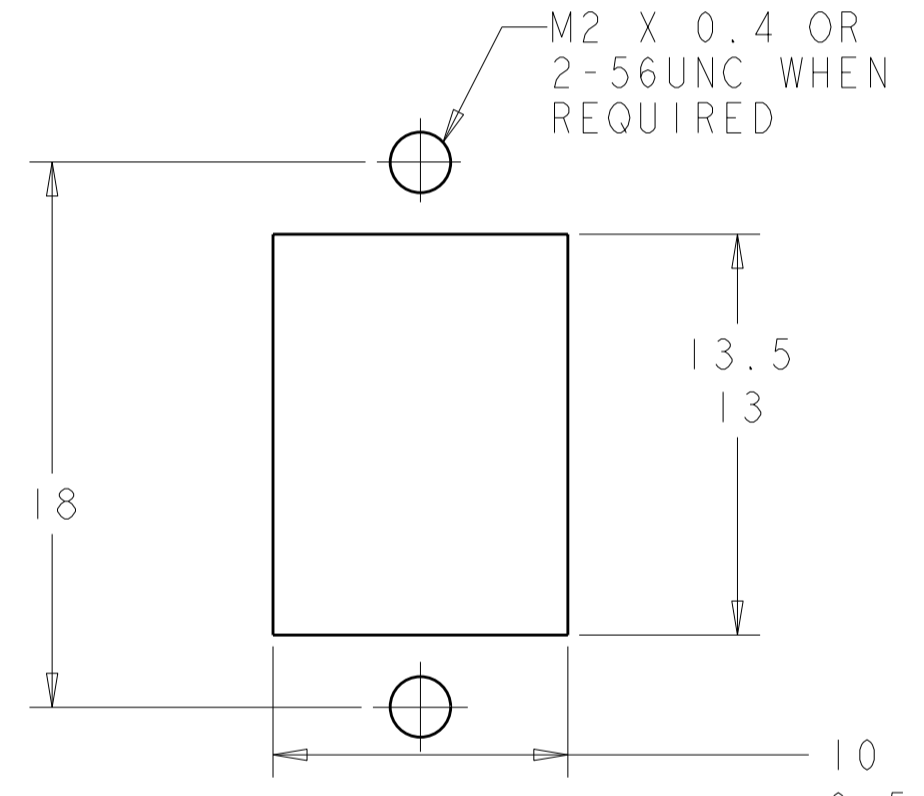
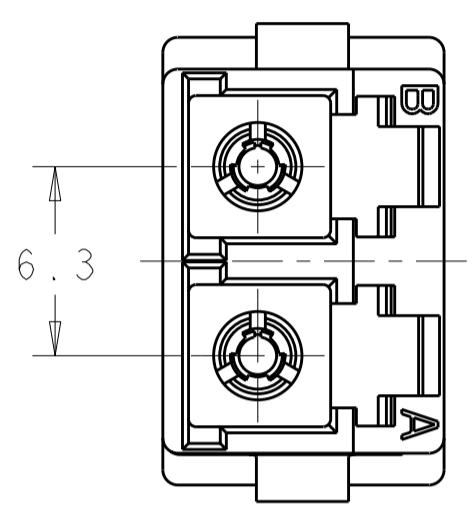
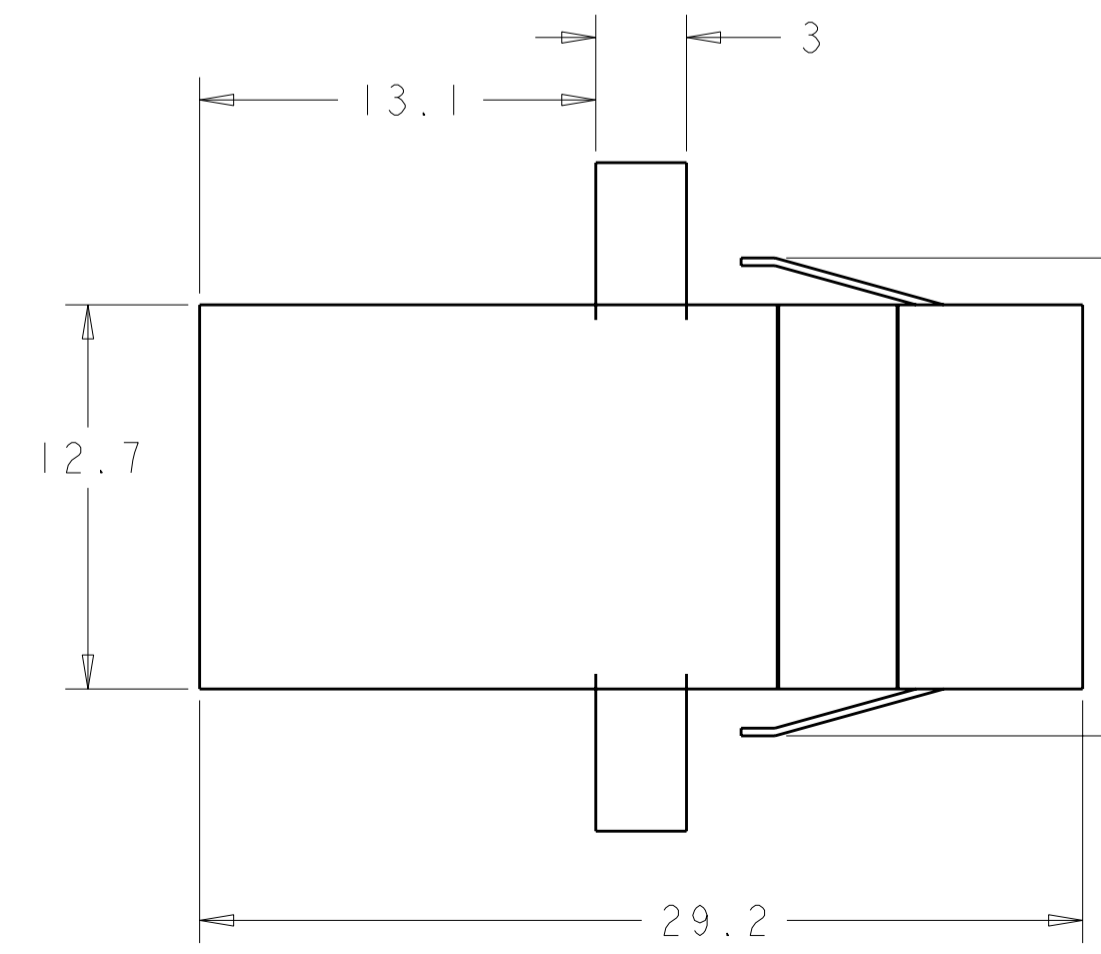
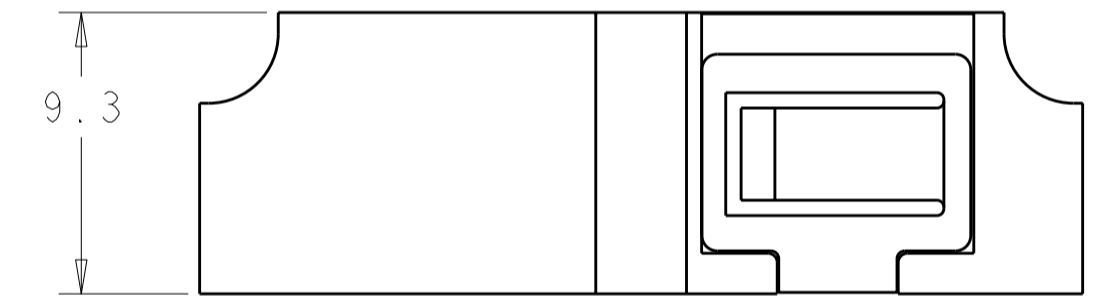
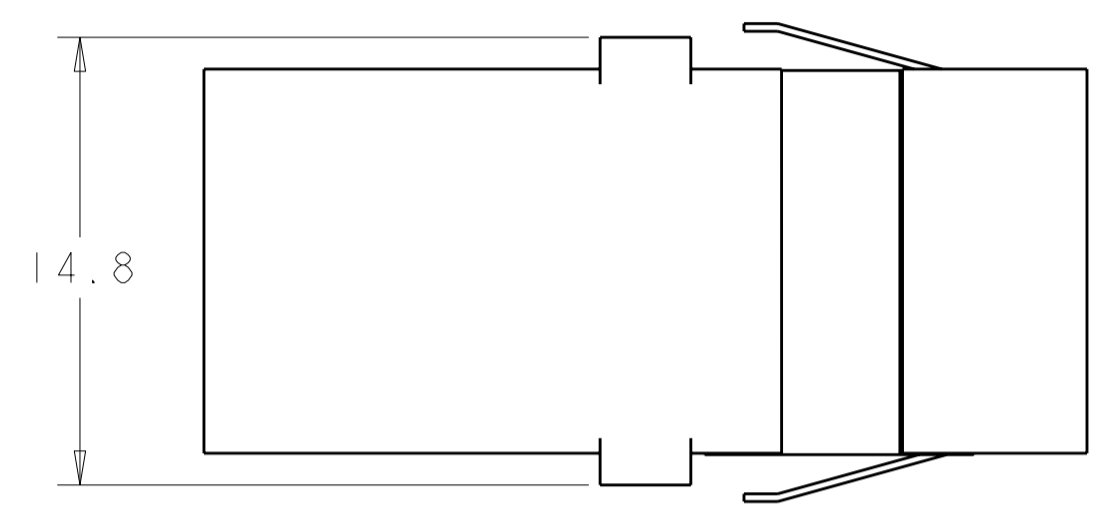
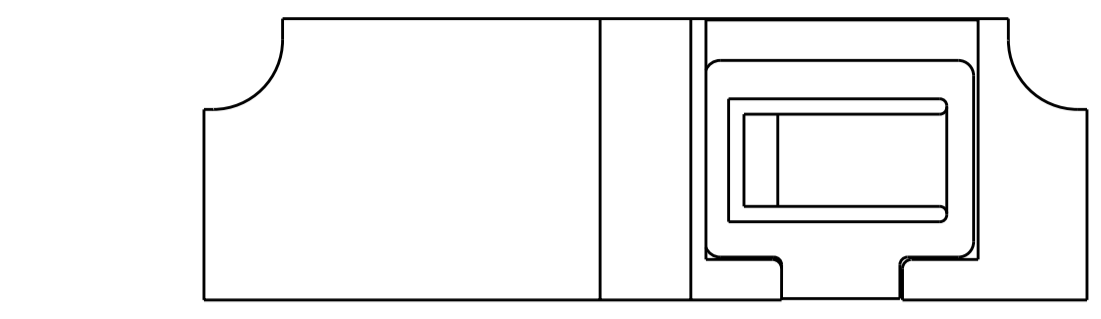

RECOMMENDED PANEL CUTOUT
 MAX PANEL THK 1.7

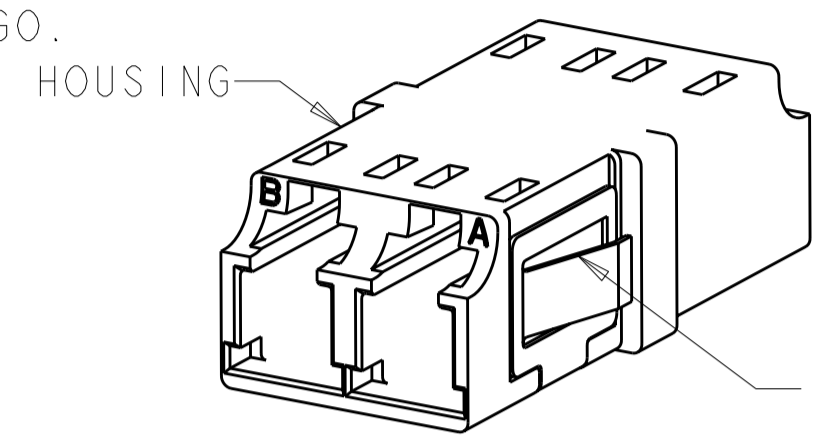
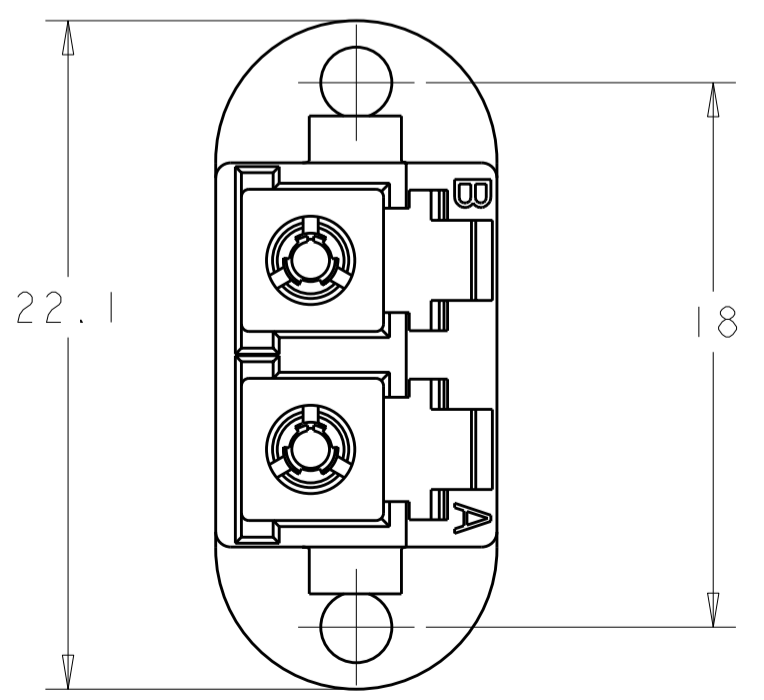

FLANGELESS
 SCALE 3:1

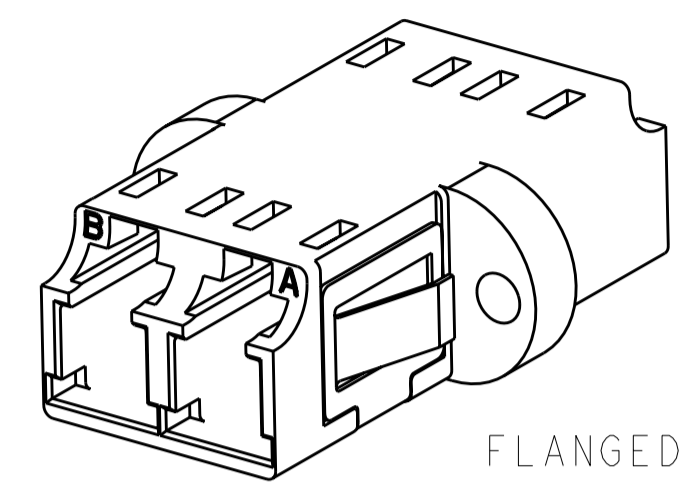

FLANGED
 SCALE 3:1

△ 4	CERAMIC	BEIGE	FLANGED	2-6457567-5
△ 4	CERAMIC	BLUE	FLANGED	2-6457567-4
△ 4	CERAMIC	BEIGE	FLANGELESS	2-6457567-3
△ 4	CERAMIC	BLUE	FLANGELESS	2-6457567-2
	METAL	BLACK	FLANGED	2-6457567-1
	METAL	AQUA	FLANGED	2-6457567-0
	METAL	BLACK	FLANGELESS	1-6457567-9
	METAL	AQUA	FLANGELESS	1-6457567-8
	CERAMIC	BLACK	FLANGED	1-6457567-7
	CERAMIC	AQUA	FLANGED	1-6457567-6
	CERAMIC	BLACK	FLANGELESS	1-6457567-5
	CERAMIC	AQUA	FLANGELESS	1-6457567-4
	METAL	BLUE	FLANGED	1-6457567-3
△ 3	CERAMIC	BLUE	FLANGELESS	1-6457567-2
△ 3	CERAMIC	BEIGE	FLANGELESS	1-6457567-1
△ 3	CERAMIC	BLUE	FLANGED	1-6457567-0
△ 3	CERAMIC	BEIGE	FLANGED	6457567-9
	METAL	BEIGE	FLANGED	6457567-8
	METAL	BEIGE	FLANGELESS	6457567-7
	CERAMIC	GREEN	FLANGED	6457567-6
	CERAMIC	BEIGE	FLANGED	6457567-5
	CERAMIC	BLUE	FLANGED	6457567-4
	CERAMIC	GREEN	FLANGELESS	6457567-3
	CERAMIC	BEIGE	FLANGELESS	6457567-2
	CERAMIC	BLUE	FLANGELESS	6457567-1

SLEEVE MAT'L HOUSING COLOR DESCRIPTION PART NUMBER

THIS DRAWING IS A CONTROLLED DOCUMENT FOR TYCO ELECTRONICS CORPORATION IT IS SUBJECT TO CHANGE AND THE CONTROLLING ENGINEERING ORGANIZATION SHOULD BE CONTACTED FOR THE LATEST REVISION.		DWN E. HOPKINS 03JUN2005 CHK D. ROHDE 03JUN2005 APVD S. BUCHTER 03JUN2005	Tyco Electronics Harrisburg, PA 17105-3608
DIMENSIONS: mm	TOLERANCES UNLESS OTHERWISE SPECIFIED: 0 PLC ±0.1 1 PLC ±0.1 2 PLC ±0.1 3 PLC ± 4 PLC ± ANGLES ± FINISH ±	PRODUCT SPEC APPLICATION SPEC WEIGHT	NAME ADAPTER, DUPLEX LC, SR-SR, SC ENVELOPE
MATERIAL			SIZE A2 CAGE CODE 00779 DRAWING NO 6457567 RESTRICTED TO CUSTOMER DRAWING SCALE 4:1 SHEET 1 OF 1 REV F